

SU-30 - Single Unit Truck
 Overall Length 30.000ft
 Overall Width 8.000ft
 Overall Body Height 13.500ft
 Min Body Ground Clearance 1.367ft
 Track Width 8.000ft
 Lock-to-lock time 5.00s
 Max Steering Angle (Virtual) 31.80°

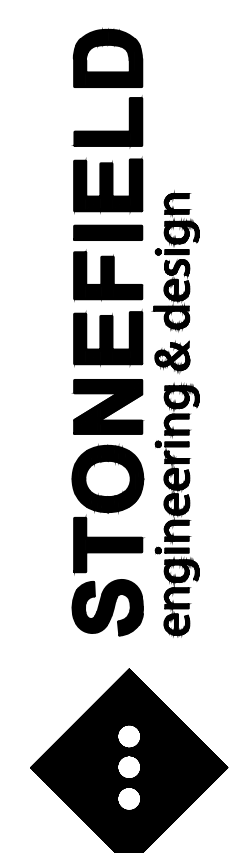
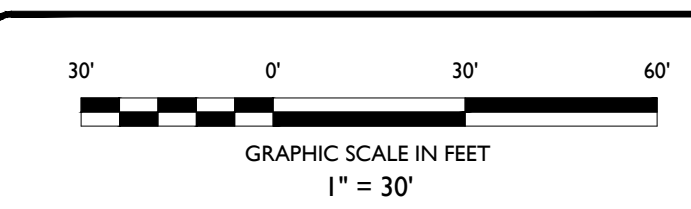
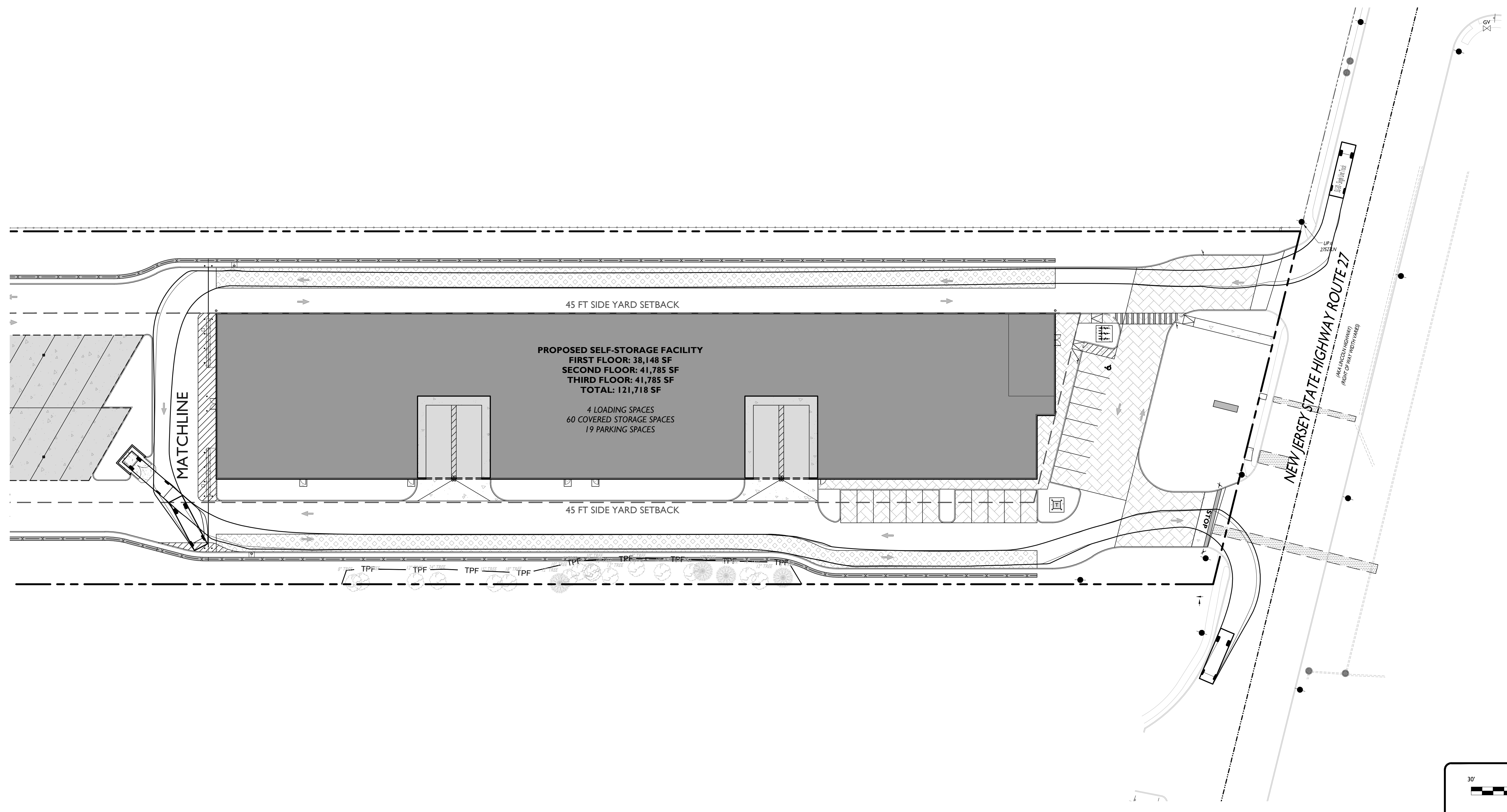

Rutherford, NJ · New York, NY · Boston, MA
 Princeton, NJ · Tampa, FL · Detroit, MI
 www.stonefieldeng.com
 15 Spring Street, Princeton, NJ 08542
 Phone 609.362.6900

TRUCK TURN EXHIBIT

ARCO MURRAY | DESIGN BUILD

PROPOSED SELF-STORAGE FACILITY
 143 LINCOLN HIGHWAY (NJ ROUTE 27)
 TOWNSHIP OF FRANKLIN
 SOMERSET COUNTY, NEW JERSEY

Joshua H. Kline
 JOSHUA H. KLINE, P.E.
 NEW JERSEY LICENSE NO. 54947
 LICENSED PROFESSIONAL ENGINEER



BY: JT CHK: BJD DATE: 02/18/2022
 SCALE: (H) 1" = 30' PROJECT ID: PRI-200094
 TITLE: **TRUCK TURN EXHIBIT (SU - 30)**
 DRAWING: **1 OF 5**

Z:\PROJECTS\PRI20094\ARCO MURRAY - 143 ROUTE 27, FRANKLIN, NJ\CADD\EXHIBIT\TRUCK TURN\SU-30.dwg

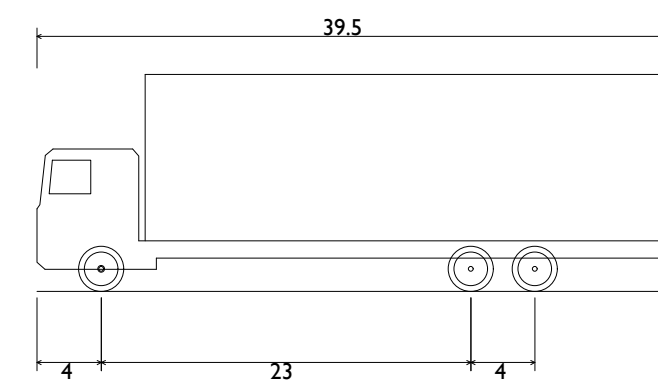
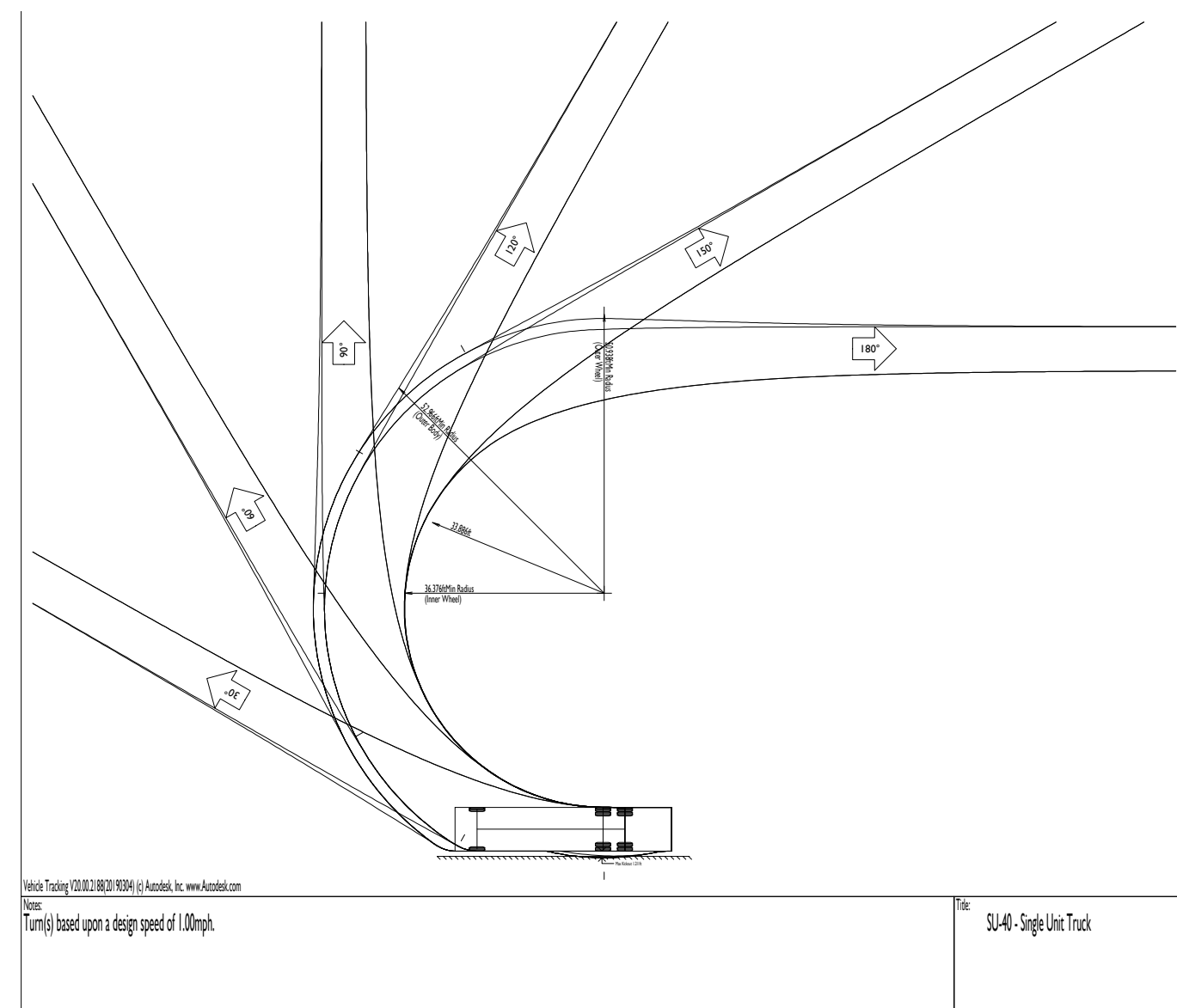
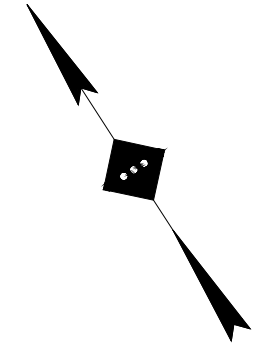

SU-40 - Single Unit Truck
 Overall Length 39.500ft
 Overall Width 8.000ft
 Overall Body Height 13.500ft
 Min Body Ground Clearance 1.367ft
 Track Width 8.000ft
 Lock-to-lock time 5.00s
 Max Steering Angle (Virtual) 31.80°

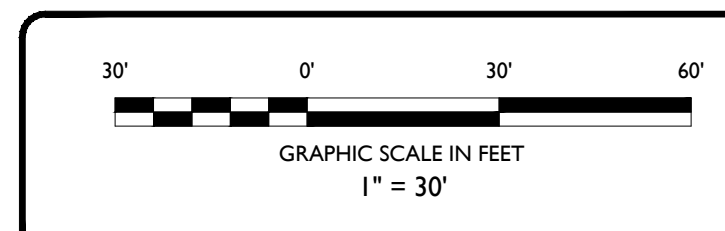
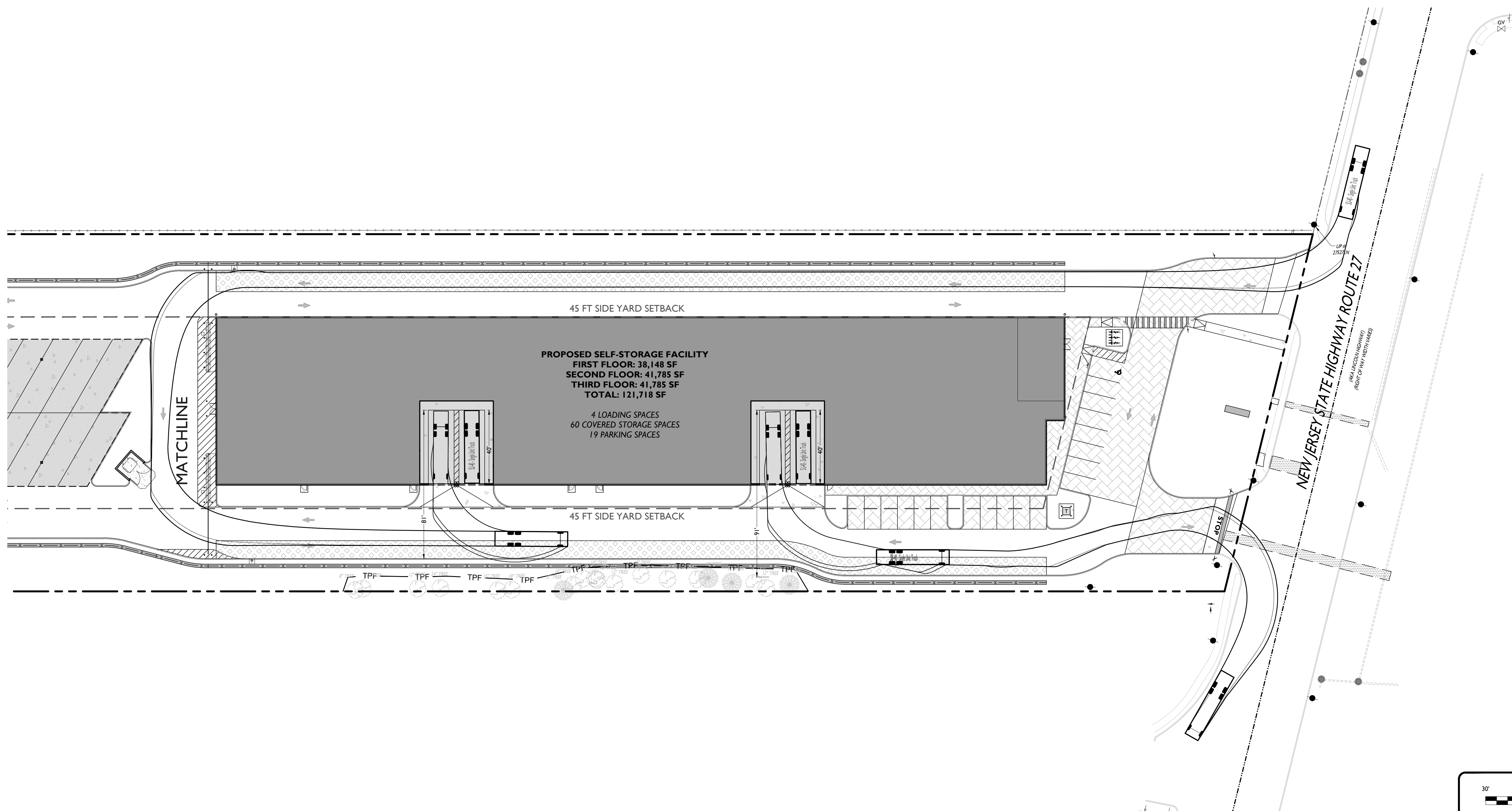

Rutherford, NJ · New York, NY · Boston, MA
 Princeton, NJ · Tampa, FL · Detroit, MI
 www.stonefieldeng.com
 15 Spring Street, Princeton, NJ 08542
 Phone 609.362.6900

TRUCK TURN EXHIBIT

ARCO MURRAY | DESIGN BUILD

PROPOSED SELF-STORAGE FACILITY
 113 LINCOLN HIGHWAY (NJ ROUTE 27)
 TOWNSHIP OF FRANKLIN
 SOMERSET COUNTY, NEW JERSEY

[Signature]
 JOSHUA H. KLINE, P.E.
 NEW JERSEY LICENSE NO. 54347
 LICENSED PROFESSIONAL ENGINEER



BY: JT CHK: BJD DATE: 02/18/2022
 SCALE: (H) 1" = 30' PROJECT ID: PRI-200094
 TITLE: **TRUCK TURN EXHIBIT (SU - 40)**
 DRAWING: **2 OF 5**

Z:\PROJECTS\PRI20094\ARCO MURRAY - 113 ROUTE 27, FRANKLIN, NJ\CADD\EXHIBIT\TRUCK TURN\SU-40.DWG

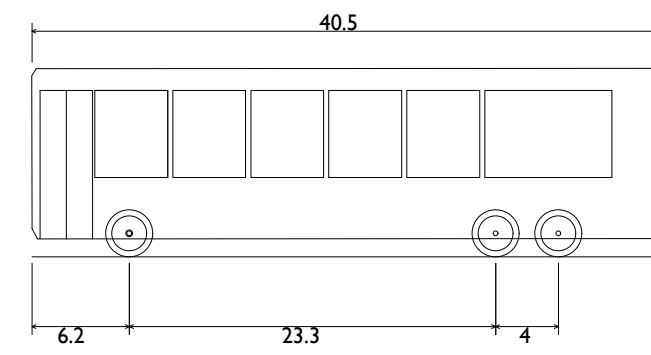
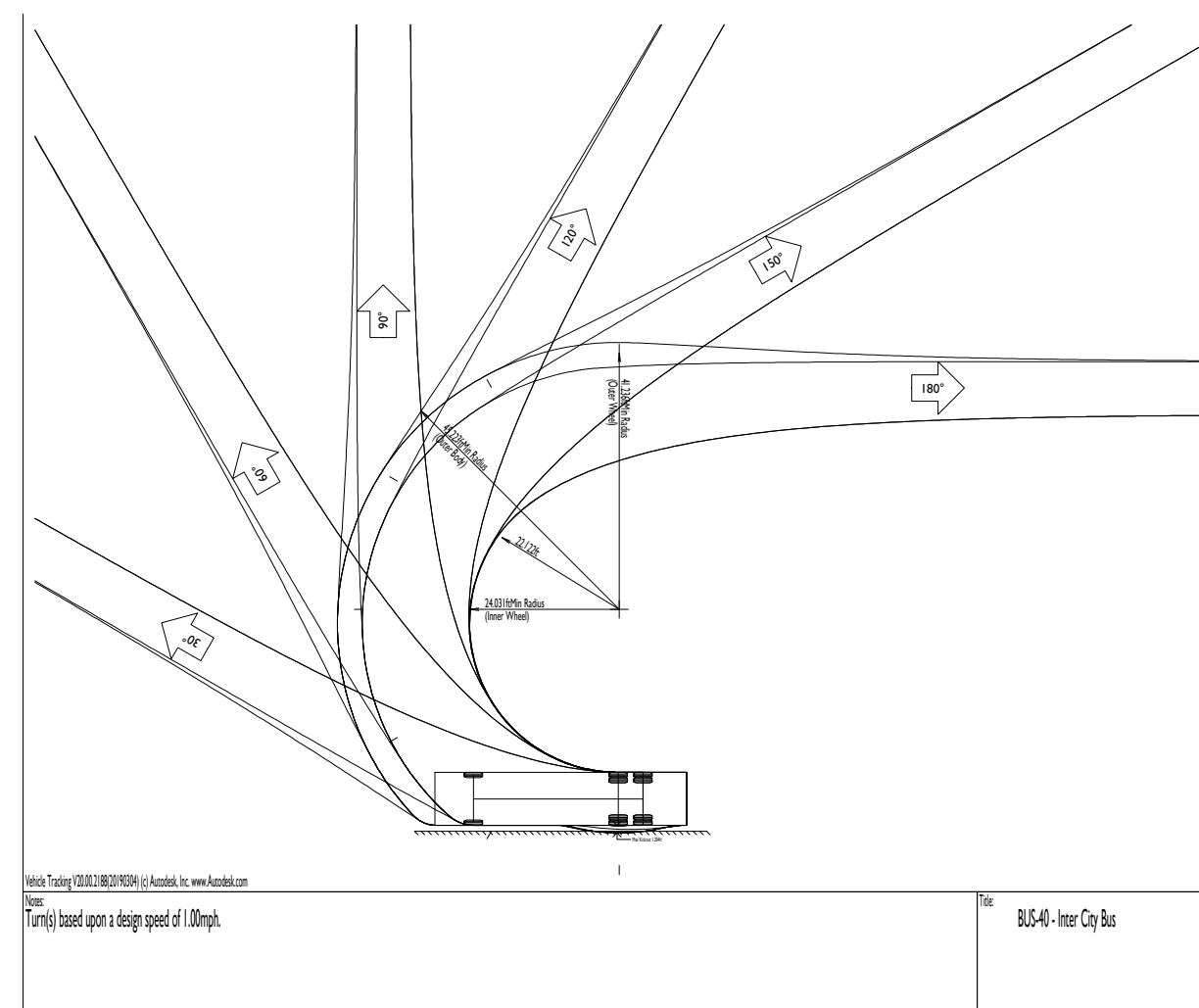
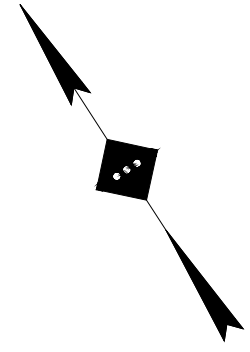

BUS-40 - Inter City Bus
 Overall Length 40.500ft
 Overall Width 8.500ft
 Overall Body Height 12.000ft
 Min Body Ground Clearance 1.158ft
 Track Width 8.500ft
 Lock-to-lock time 5.00s
 Max Steering Angle (Virtual) 41.90°

804-Inter City Bus

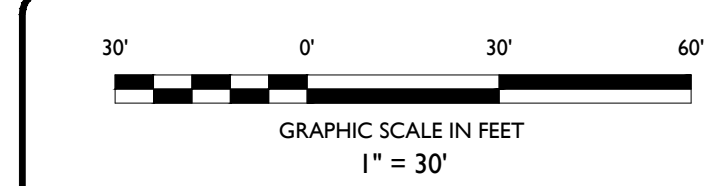
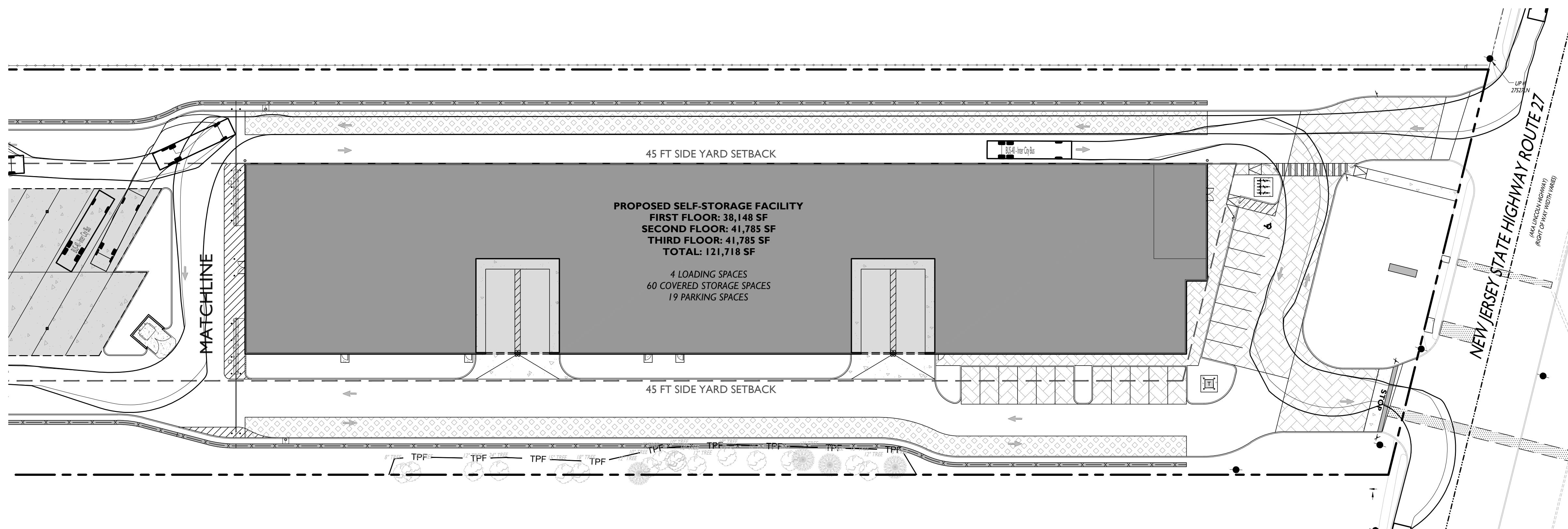
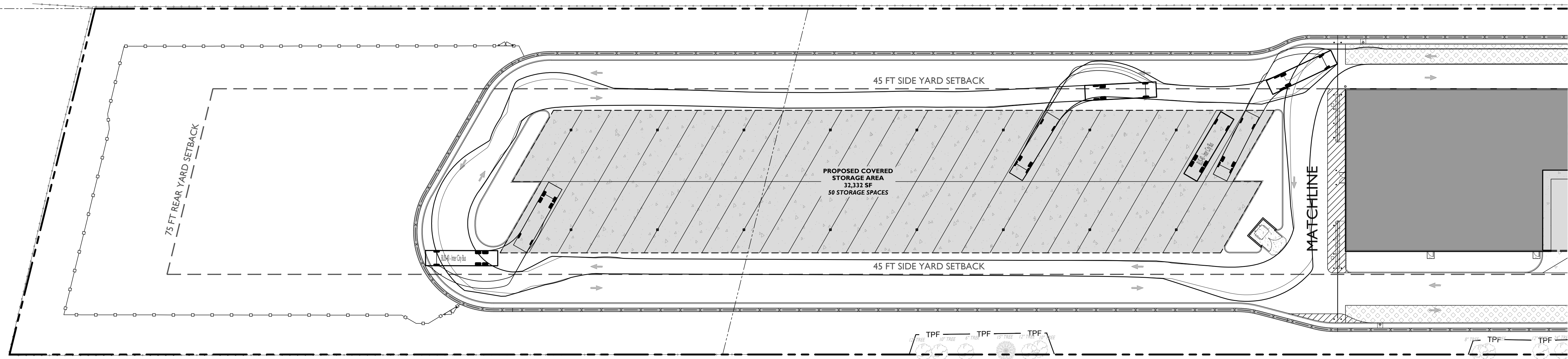

STONEFIELD
engineering & design

Rutherford, NJ · New York, NY · Boston, MA
Princeton, NJ · Tampa, FL · Detroit, MI
www.stonefielddesign.com

15 Spring Street, Princeton, NJ 08542
Phone 609.362.6900

TRUCK TURN EXHIBIT

ARCO
MURRAY | DESIGN BUILD

PROPOSED SELF-STORAGE FACILITY
BLANKS LANE
1433 LINCOLN HIGHWAY (NJ ROUTE 27)
TOWNSHIP OF FRANKLIN
SOMERSET COUNTY, NEW JERSEY

JOSHUA H. KLINE, P.E.
NEW JERSEY LICENSE NO. 54947
LICENSED PROFESSIONAL ENGINEER

STONEFIELD
engineering & design

BY: JT CHK: BJD DATE: 02/18/2022

SCALE: (H) 1" = 30' PROJECT ID: PRI-200094

TITLE: **TRUCK TURN EXHIBIT (BUS - 40)**

DRAWING:

3 OF 5

Z:\PROJECTS\PRI200094\ARCO MURRAY - 1433 ROUTE 27, FRANKLIN, NJ\CADD\EXHIBIT\TRUCK TURN\2022\02-18-22\1433 TRUCK TURN, FRANKLIN, NJ.DWG

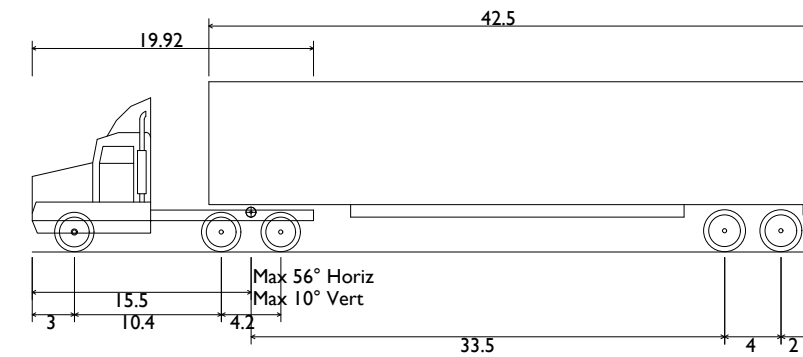
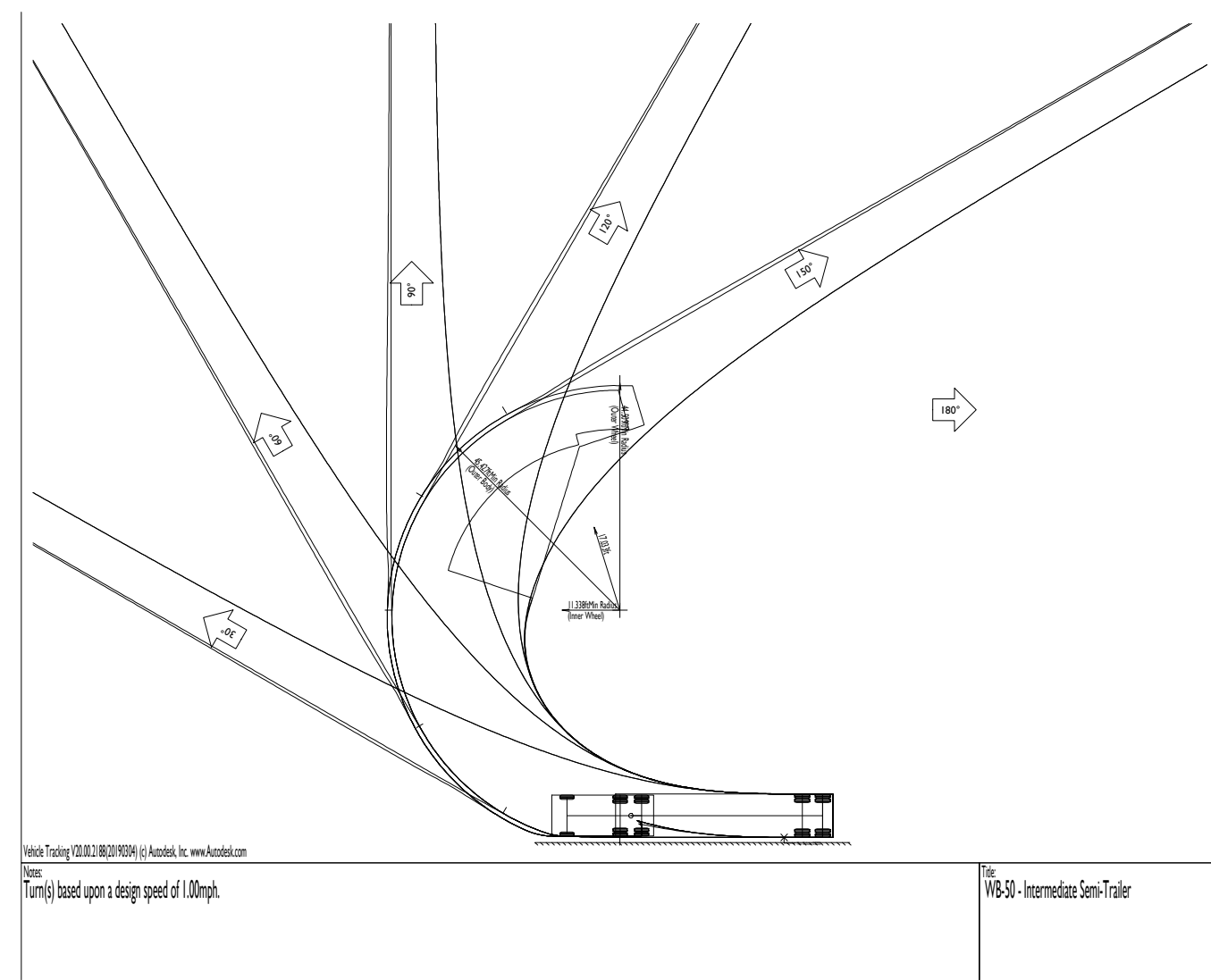
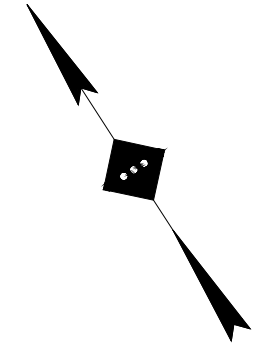

WB-50 - Intermediate Semi-Trailer
 Overall Length 55.000ft
 Overall Width 8.500ft
 Overall Body Height 12.052ft
 Min Body Ground Clearance 1.334ft
 Max Track Width 8.500ft
 Lock-to-lock time 6.00s
 Max Steering Angle (Virtual) 17.90°

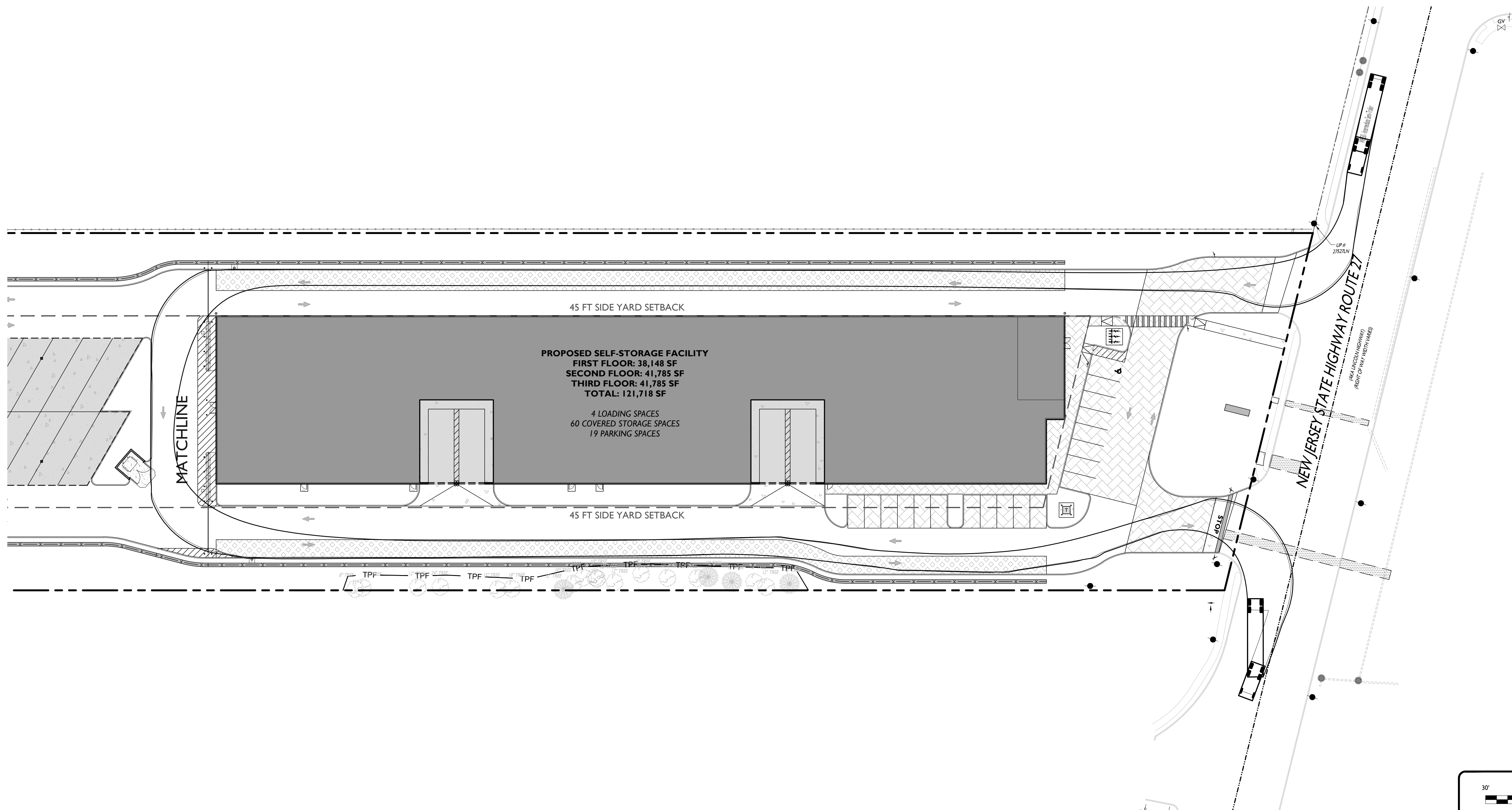

PROPOSED SELF-STORAGE FACILITY
 FIRST FLOOR: 38,148 SF
 SECOND FLOOR: 41,785 SF
 THIRD FLOOR: 41,785 SF
 TOTAL: 121,718 SF

4 LOADING SPACES
 60 COVERED STORAGE SPACES
 19 PARKING SPACES

45 FT SIDE YARD SETBACK

NEW JERSEY STATE HIGHWAY ROUTE 27
 (INCLUDING HIGHWAY)
 (ABOUT 27' FROM CENTERLINE)

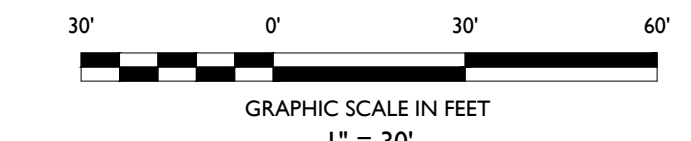

STONEFIELD
 engineering & design

Rutherford, NJ · New York, NY · Boston, MA
 Princeton, NJ · Tampa, FL · Detroit, MI
 www.stonefieldeng.com

15 Spring Street, Princeton, NJ 08542
 Phone 609.362.6900

TRUCK TURN EXHIBIT

ARCO
MURRAY
 | DESIGN BUILD

PROPOSED SELF-STORAGE FACILITY
 1143 LINCOLN HIGHWAY (NJ ROUTE 27)
 TOWNSHIP OF FRANKLIN
 SOMERSET COUNTY, NEW JERSEY

J.H. Kline
 JOSHUA H. KLINE, P.E.
 NEW JERSEY LICENSE NO. 54347
 LICENSED PROFESSIONAL ENGINEER

STONEFIELD
 engineering & design

BY: JT CHK: BJD DATE: 02/18/2022

SCALE: (H) 1" = 30' PROJECT ID: PRI-200094

TITLE: **TRUCK TURN EXHIBIT (WB - 50)**

DRAWING: **4 OF 5**

Z:\PROJECTS\PRI20094\ARCO MURRAY - 1143 ROUTE 27, FRANKLIN, NJ\CADD\HBITRUCK TURN EXHIBIT.DWG

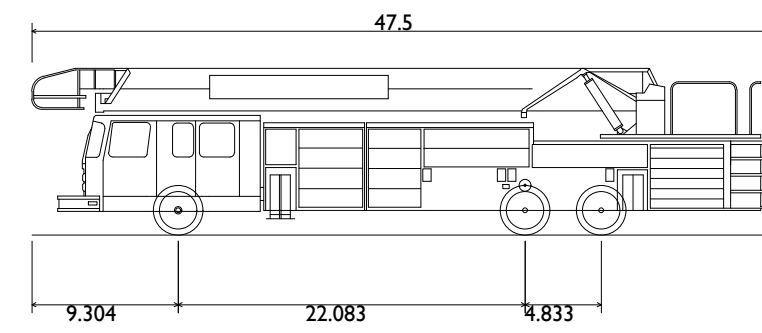
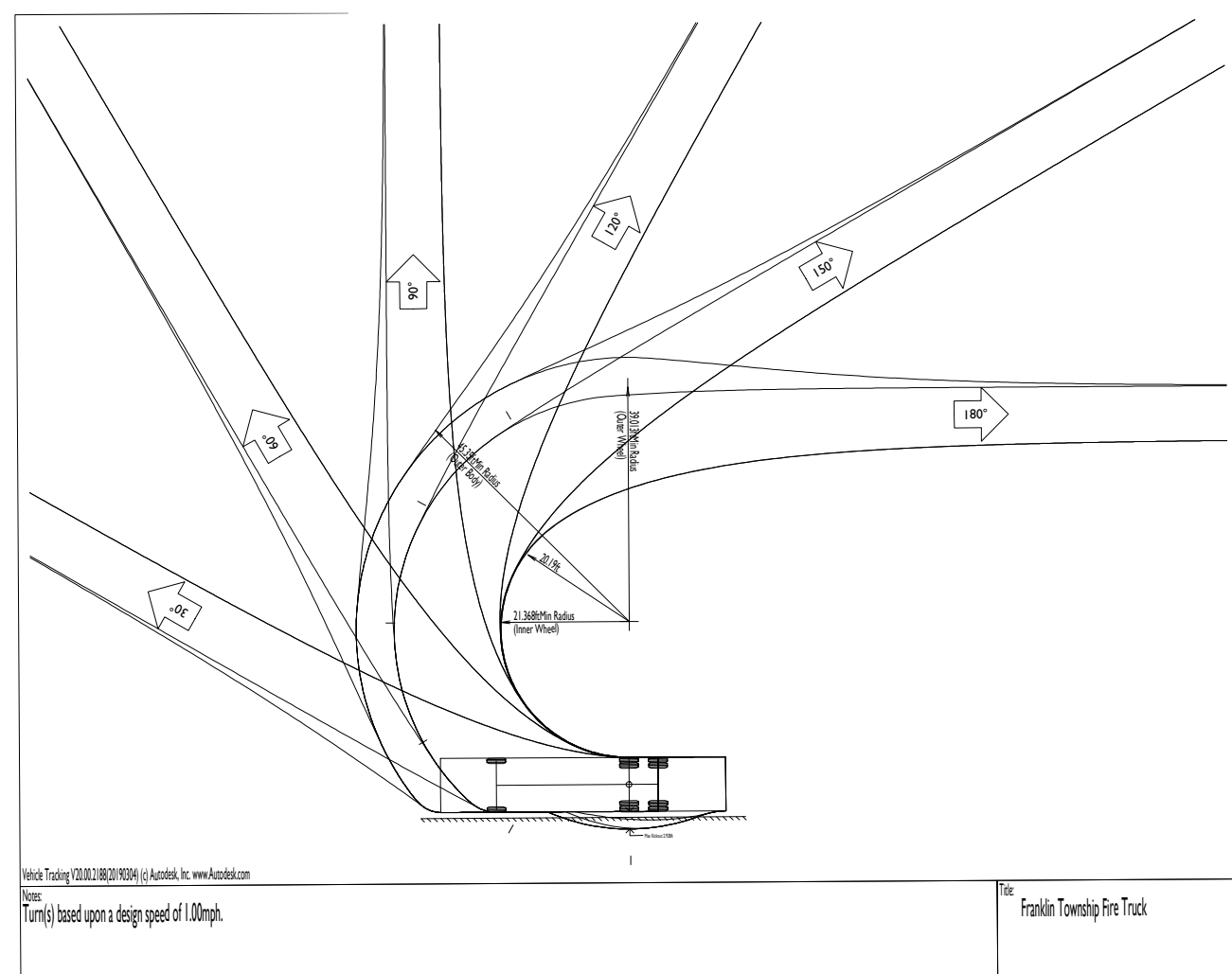
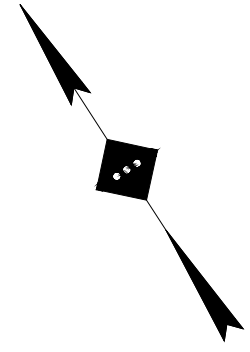

Franklin Township Fire Truck
 Overall Length 47.500ft
 Overall Width 9.000ft
 Overall Body Height 10.607ft
 Min Body Ground Clearance 1.037ft
 Track Width 9.000ft
 Lock-to-lock time 6.00s
 Wall to Wall Turning Radius 45.350ft

Note: Truck based upon a design speed of 100mph.
 Franklin Township Fire Truck

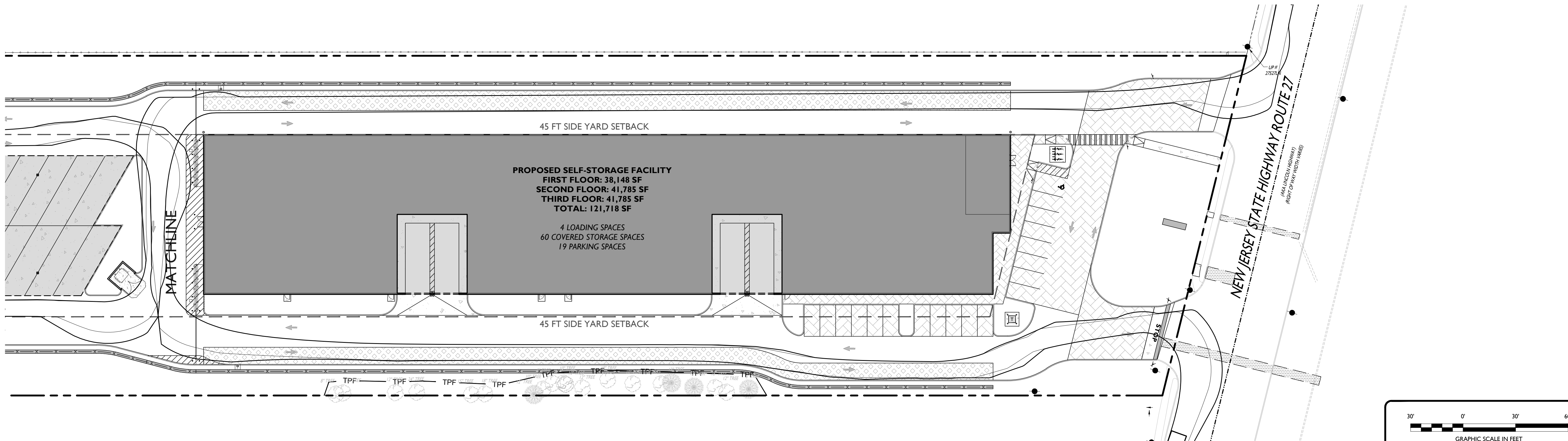
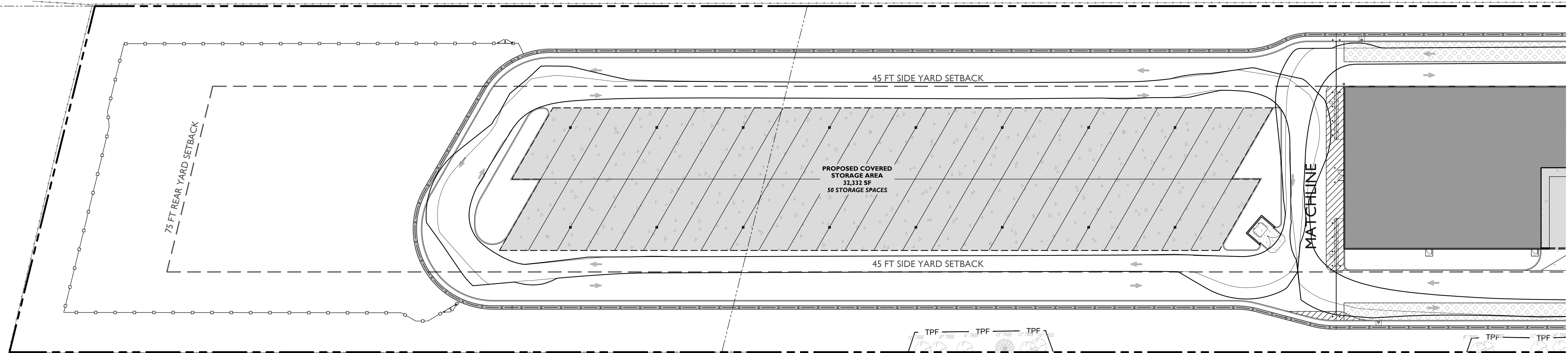

PROPOSED SELF-STORAGE FACILITY
 FIRST FLOOR: 38,148 SF
 SECOND FLOOR: 41,785 SF
 THIRD FLOOR: 41,785 SF
 TOTAL: 121,718 SF
 4 LOADING SPACES
 60 COVERED STORAGE SPACES
 19 PARKING SPACES

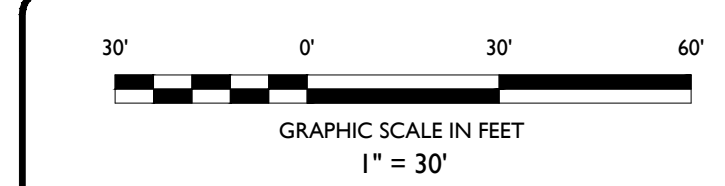

STONEFIELD
 engineering & design

Rutherford, NJ · New York, NY · Boston, MA
 Princeton, NJ · Tampa, FL · Detroit, MI
 www.stonefielddesign.com
 15 Spring Street, Princeton, NJ 08542
 Phone 609.362.6900

TRUCK TURN EXHIBIT
ARCO
MURRAY
 | DESIGN BUILD

PROPOSED SELF-STORAGE FACILITY
 163 LINCOLN HIGHWAY (NJ ROUTE 27)
 TOWNSHIP OF FRANKLIN
 SOMERSET COUNTY, NEW JERSEY

JOSHUA H. KLINE, P.E.
 NEW JERSEY LICENSE NO. 54947
 LICENSED PROFESSIONAL ENGINEER

STONEFIELD
 engineering & design

BY: JT CHK: BJD DATE: 02/18/2022
 SCALE: (H) 1" = 30' PROJECT ID: PRI-200094

TITLE: **TRUCK TURN EXHIBIT (FIRE)**

DRAWING: **5 OF 5**

Z:\PROJECTS\PRI200094\ARCO MURRAY - 163 ROUTE 27, FRANKLIN, NJ\CADD\EXHIBIT\TRUCK TURN EXHIBIT.DWG (R) 02/18/2022 02:18:10 JT TRUCK TURN, FRANKLIN, NJ DWG